

valve housing, without cover

- Aluminum
- for 581
- size 1
- standard ISO 5599-1

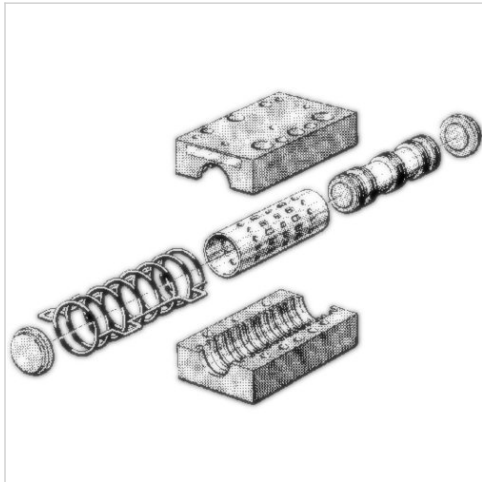

standard	ISO 5599-1
Ambient temperature min./max.	-20 ... 70 °C
Medium	Compressed air
Max. particle size	50 µm
Oil content of compressed air	40 ... 400 mg/m³
Weight	See table below

Technical data

Part No.	Type	Weight
5811100000	5/2-directional valve, mono-stable	0,27 kg
5811200000	5/2-directional valve, double solenoid	0,27 kg
5811300000	5/2-directional valve, double solenoid, with manual override	0,27 kg
5811400000	5/3-directional valve, closed center	0,15 kg
5811500000	5/3-directional valve, exhausted center	0,2 kg
5811600000	5/2-way solenoid valve, with differential piston	0,2 kg
5811700000	5/3-directional valve, pressurized center	0,14 kg

The valve can be changed to a single solenoid version with air return., signal 14 has priority

Technical information

Material	
Housing	Aluminum