

Check-choke valve, stainless steel, Series CC02-SL

- Qn 2►1 = 350 l/min
- direction of throttle 2 ► 1
- exhaust air throttling
- External thread



Working pressure min./max.	0,5 ... 10 bar
Ambient temperature min./max.	-20 ... 150 °C
Medium temperature min./max.	-20 ... 200 °C
Medium	Compressed air
Weight	See table

The delivered product varies from that in the illustration. See the drawing for an exact description.

Technical data

Part No.	Port 2	Throttle bore	Flow	Weight
		Ø	Qn 2►1	
R412004980	G 1/8	3 mm	350 l/min	0,018 kg
R412004981	G 1/4	4,5 mm	600 l/min	0,033 kg

Technical information

Only applicable in combination with banjo union (see accessories)

Technical information

Material	
Housing	Stainless steel
Flow control screw	Stainless steel
Seals	Fluorocaoutchouc

Dimensions

Dimensions

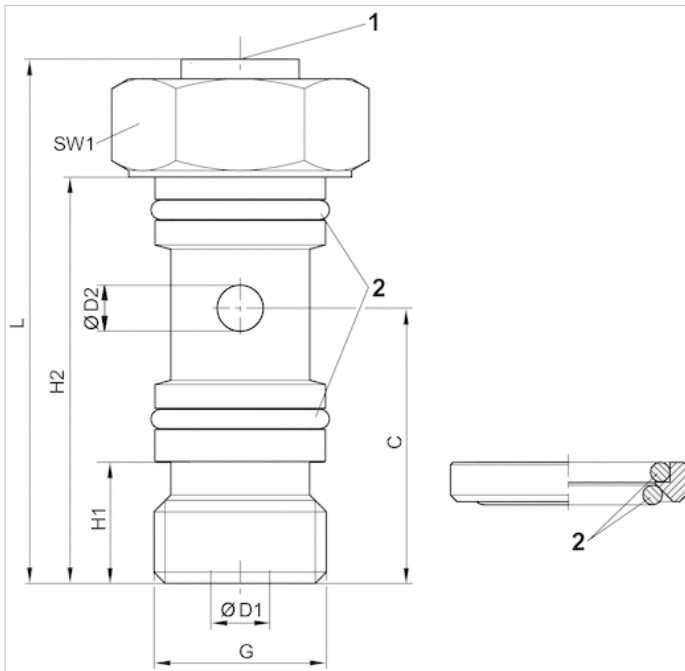

- 1) Slot in throttle screw 1 mm
- 2) Sealing ring

Dimensions

Part No.	G	Ø D1	Ø D2	H1	H2	L 1)	C	SW1
R412004980	G 1/8	3	3	7.8	25	32	17.5	14
R412004981	G 1/4	4.5	3.5	9.25	31	40	21	17

1) Max.